



AMERICAN SPECIALTIES, INC.

441 Saw Mill River Road, Yonkers, NY 10701 (914) 476-9000

MODEL No: 1204

ISSUED: 1-87

REVISED: 3-99

EXTRA HEAVY-DUTY SHOWER CURTAIN ROD WITH EXPOSED MOUNTING FLANGES

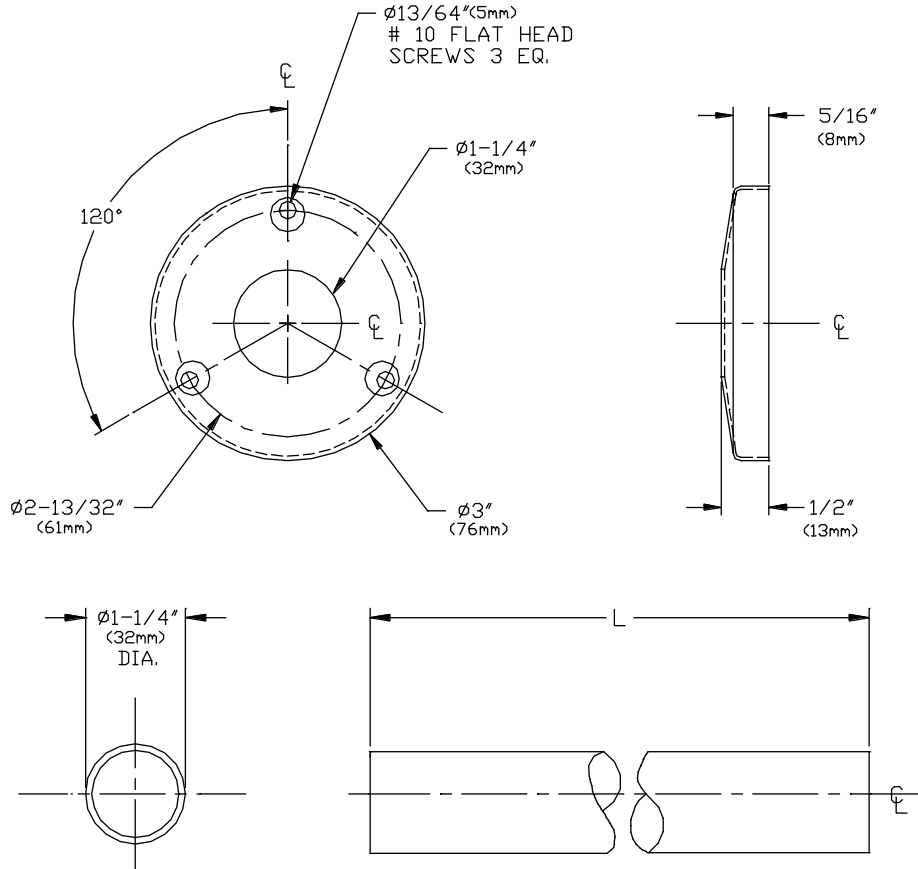

SPECIFICATION

Extra-Heavy-Duty Shower Curtain Rod with flanges shall be fabricated of alloy 18-8 stainless steel, type 304. Tubing shall be N^o18 gauge, 1-1/4" O.D. with a satin finish and shall be protected during shipment with a plastic bag. Length shall be as specified. Flanges shall be fabricated of 20ga. stainless steel with a satin finish. Flanges shall have (3) countersunk 13/64" (5.2mm) dia. holes to accept #10 flat or oval head screws furnished by others.

Extra-Heavy-Duty Shower Curtain Rod with Exposed Mounting Flanges shall be Model N^o 1204- XXX as fabricated by American Specialties, Inc., 441 Saw Mill River Road, Yonkers, New York 10701-4913

ORDERING NOTE

Select length in inches (i.e. 48, 60, 120) to create Part Spec Order Number (i.e. 1204- 60).

INSTALLATION

Rod is installed in straight section between two (2) mounting flanges. Rods longer than 72" (1829mm) require ceiling hanger Model N^o 1204-C18. For use with standard shower curtain model N^o's 1200 or 1200-V having 72" (1829mm) length and standard hooks Model N^o1200-SHU unit should be installed with rod centerline 74-1/2" (1892mm) AFF or 67" (1702mm) above tub rim to obtain 6" (152mm) bottom overlap.

Accessory Specialties

AMERICAN DISPENSER

Desert Ray Products

WATROUS INC.