



AMERICAN SPECIALTIES, INC.

441 Saw Mill River Road, Yonkers, NY 10701 (914) 476-9000

MODEL No: 0852

ISSUED: 1-87

REVISED: 8-98

SURFACE MOUNTED SANITARY NAPKIN DISPOSAL

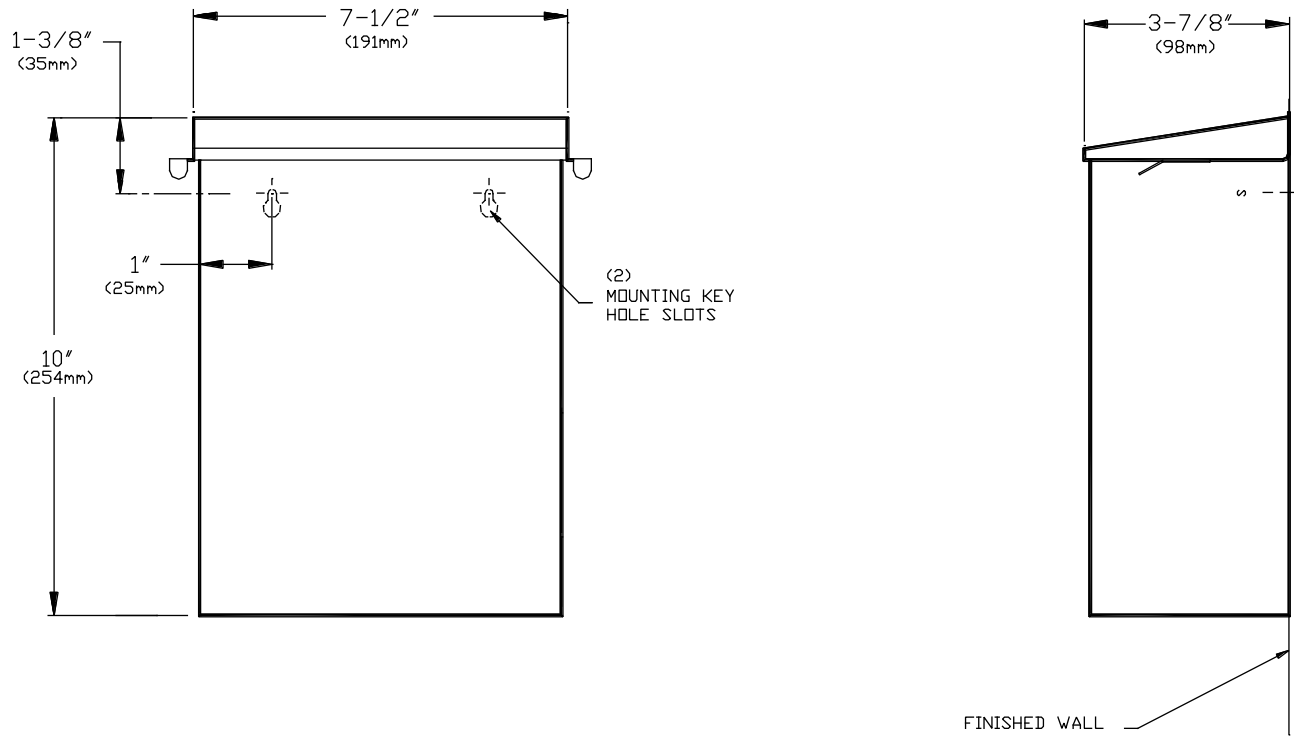

SPECIFICATION

Surface Mounted Sanitary Napkin Disposal shall have door and cabinet fabricated of alloy 18-8 stainless steel, type 304, №22 gauge. All exposed surfaces shall be №4 satin finish and be protected during shipment with a PVC film easily removable after installation. Top cover is attached to cabinet with a full length 3/16" dia. stainless steel multi-staked piano hinge. Structural assembly of body and door components shall be of welded construction. Top cover shall have lift handles at each end fabricated as one piece with top.

Surface Mounted Sanitary Napkin Disposal shall be Model № 0852 as fabricated by American Specialties, Inc. 441 Saw Mill River Road Yonkers, New York 10701-4913

INSTALLATION

Unit is surface mounted on wall or partition №10 self tapping screws (supplied). Two (2) mounting holes through back are "keyhole" slots for ease in hanging unit on pre-installed screws. For compliance with ADA Accessibility Guidelines, unit should be installed so that top cover is 30" (762mm) above finished floor.

OPERATION

User lifts lid to deposit waste material. Maintenance schedule determines trash removal cycle. Unit is emptied by top door and removing wax paper collection bag. Waxed paper liner bags are furnished by janitorial personnel.

Accessory Specialties

AMERICAN DISPENSER

Desert Ray Products

WATROUS INC.