



AMERICAN SPECIALTIES, INC.

441 Saw Mill River Road, Yonkers, NY 10701 (914) 476-9000

MODEL No: 0464

ISSUED: 1-87

REVISED: 3-99

RECESSED NAPKIN / TAMPON DISPENSER (PAGE 1 OF 2)

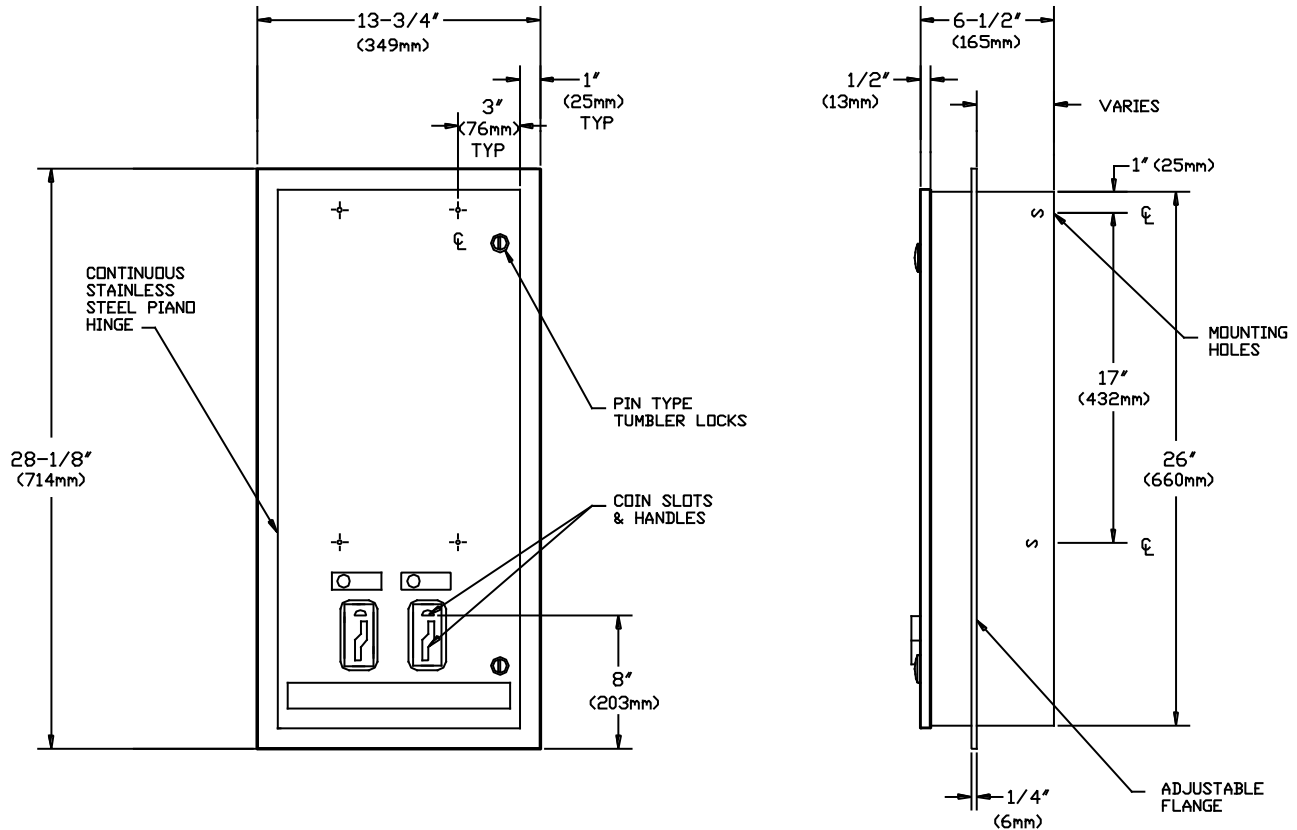

SPECIFICATION

Recessed Napkin / Tampon Dispenser shall hold 30 napkins and 27 tampons of specified sizes and shall have cabinet and flange fabricated of alloy 18-8 stainless steel, type 304, №22 gauge; all exposed surfaces shall have № 4 satin finish and be protected during shipment by plastic PVC film easily removed after installation. Doors shall be fabricated of №18 gauge same grade stainless steel and shall be attached to cabinet with a full length 3/16" dia. (5mm) stainless steel multi-staked piano hinge and shall be held closed with two (2) tumbler locks keyed alike to other ASI washroom equipment. Internal coin-box shall be keyed differently than door locks. Dispensing mechanisms shall be fastener mounted internally to provide ability to change mechanisms for coinage denomination. Structural assembly of body and door components shall be of welded construction and have no exposed fasteners or welded seams. Weights for each feed track shall be supplied. Factory installed coin operation denomination shall be _____ (please fill in 25¢ or 50¢ or FREE) and add denomination as suffix to model № (ie: 0464-25).

Recessed Napkin / Tampon Dispenser shall be Model № 0464-XX as manufactured by American Specialties, Inc., 441 Saw Mill River Road, Yonkers, New York 10701-4913

INSTALLATION

Unit is mounted in wall recess using №10 self-tapping screws (supplied). For maximum usability and compliance with ADA Accessibility Guidelines, unit should be installed so that coin slot is between 54" (1372mm) maximum above finished floor (AFF) and 38" (965mm) minimum AFF. Note that coin slot is 7-1/4" (184mm) above bottom edge of RWO, bottom flange is 3/4" (19mm) below bottom edge of RWO.

Rough Wall Opening (RWO) required is.... 12-1/2"W x 26-5/8"H x 2" min. to 6" max. D (318mm x 676mm x 25mm to 153mm).

Accessory Specialties

AMERICAN DISPENSER

Desert Ray Products

WATROUS INC.



AMERICAN SPECIALTIES, INC.

441 Saw Mill River Road, Yonkers, NY 10701 (914) 476-9000

MODEL No: 0464

ISSUED: 1-87

REVISED: 3-99

RECESSED NAPKIN / TAMPON DISPENSER (PAGE 2 OF 2)

OPERATION

Deposit of specified coin allows operation of dispenser. Napkin and tampon dispensers operate independently. Selected product drops into vending opening after operator actuation. Indicator displays empty condition and blocks coin slot when product is depleted. Unit vend product supply is replenished on cycle determined by maintenance needs by opening door and manually reloading product into dispenser supply tracks. Track weights MUST BE USED to provide positive feed.

**NAPKINS, SINGLES, CARDBOARD-BOXED, SEMIGLOSS FINISH; CAPACITY: 30
BOX SIZE : 4-1/4" x 3" x 1-1/8" (108mm x 76mm x 29mm)**

Stayfree	Nº 4
Guards	Nº's 247, or 147
Kotex	Nº's 704, 707, 07010, 07040, 07045, 07300, 07320
Pure-Nat	Nº M-4
Modess	Nº 4

**TAMPONS, CYLINDER, CARDBOARD, SEMIGLOSS, CRIMPED ENDS; CAPACITY: 27
TUBE SIZE: 3/4" dia. x 5-1/4" (19mm x 134mm)**

Tampax
Modess Tampons