



AMERICAN SPECIALTIES, INC.
441 Saw Mill River Road, Yonkers, NY 10701 (914) 476-9000

MODEL No: 0452

ISSUED: 1-87

REVISED: 9-96

RECESSED PAPER TOWEL DISPENSER

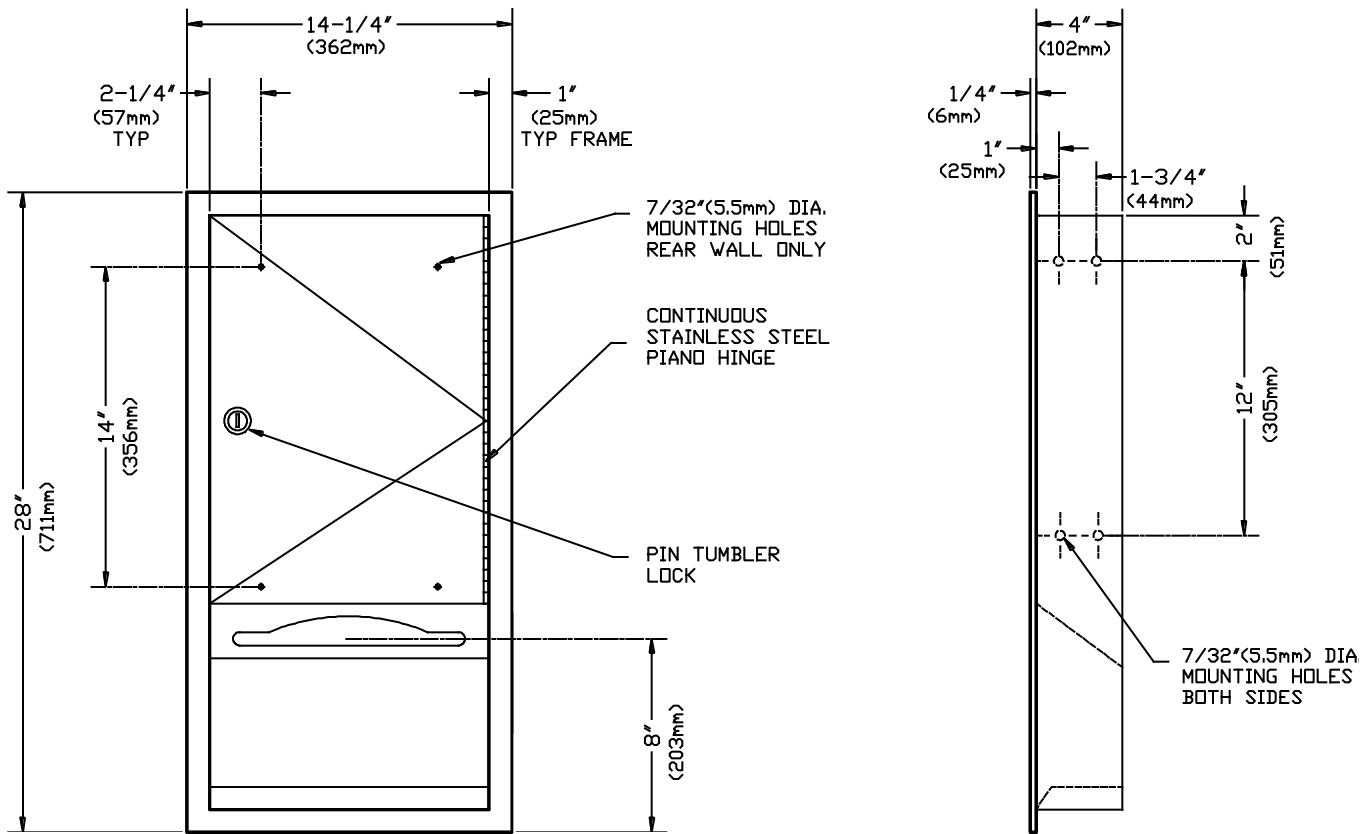

SPECIFICATION

Recessed Paper Towel Dispenser shall hold and dispense 800 standard multi-fold or 600 standard C-fold paper towels. Towel dispenser, door, frame and cabinet shall be fabricated of alloy 18-8 stainless steel, type 304, No 22 gauge. All exposed surfaces shall be N° 4 satin finish and be protected during shipment with a PVC film easily removable after installation. Towel dispensing slot shall have a fully hemmed-in rolled edge for snag-free dispensing and user safety. Door shall be fabricated in double-pan construction with a fiberboard filler and shall be attached to cabinet at side with a full length 3/16" dia. (4.8mm) stainless steel multi-staked piano hinge and be held closed with a tumbler lock keyed alike to other ASI Washroom Equipment. Face trim shall be 1" (25.4mm) wide formed from one piece with no mitres, welding or open seams and have 1/4" (6.35mm) square return to wall. Structural assembly of all components shall be of welded construction.

Recessed Paper Towel Dispenser shall be Model N° 0452 as fabricated by American Specialties, Inc. 441 Saw Mill River Road, Yonkers, New York 10701-4913

INSTALLATION

Unit is recessed mounted in wall using N°10 self tapping screws (supplied) through concealed mounting holes provided. For compliance with ADA Accessibility Guidelines, unit should be installed so that towel dispenser slot is 54" (1372mm) maximum above finished floor (AFF) if clear floor side reach access is provided or 48" (1219mm) maximum AFF if clear floor forward reach access only is provided.

Rough wall opening (RWO) required is 12-3/4" W x 26-1/2" H x 4" D minimum (324mm x 673mm x 102mm)

OPERATION

Towels are self-feeding until supply is depleted. Unit may be reloaded with a partial load in-place and will continue to feed properly.

Accessory Specialties

AMERICAN DISPENSER

Desert Ray Products

WATROUS INC.